

Unclassified



DoD Chief Information Officer

DoD Information Enterprise Architecture (DIEA) and the DoD Business Capability Acquisition Cycle (BCAC)

2018-02-06

Unclassified



Brief Outline

- DIEA v3.0 Status and Plans Overview
- DoDI 8270, “DoD Architectures” (DRAFT)
- Integration of DIEA into BEA supporting BCAC



Architecture for the DoD Information Enterprise: Current and Future

- Current IEA v2.0:
 - Multiple documents
 - DoD IEA v2.0 and JIE EA v0.4
 - 10 reference-like documents
 - 50 solution-like documents
 - Procedures for use are imprecise and manual
- Future IEA v3.0:
 - Single, coordinated organizing construct:
 - Overview document
 - Integrated architecture data
 - Well-defined uses supported
 - Automated functionality
 - Development Phases
 - Phase 1 - CY2017
 - Phase 2 - CY2018



Scope of DoD Information Enterprise

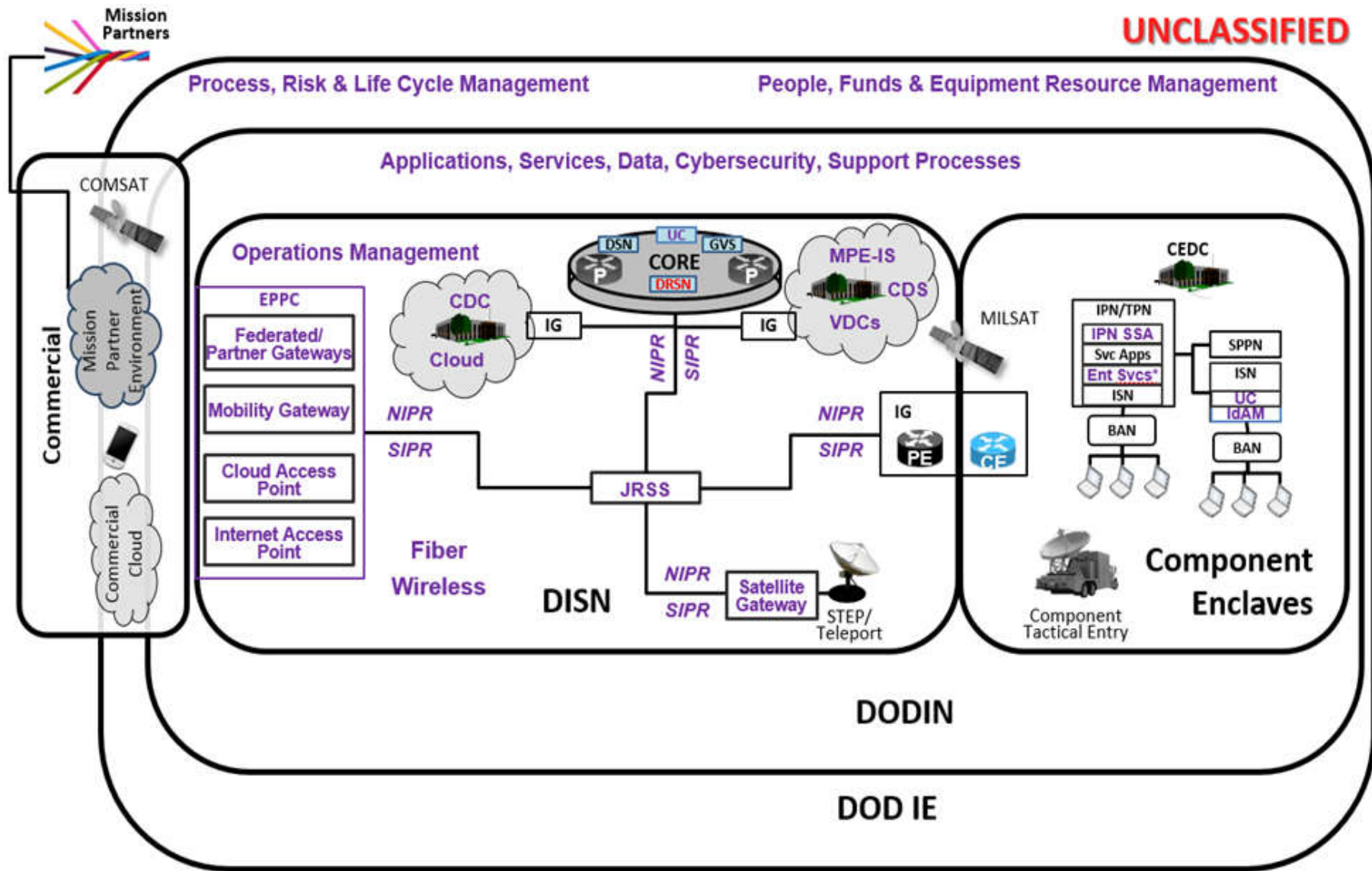

UNCLASSIFIED

UNCLASSIFIED

JIE Impact Areas

From "Achieving the JIE Vision"



DIEA Content is Determined by Usage

Driver
Achieving the JIE Vision
Clinger Cohen Act
Cyberspace Operations- JR 3-12
DoD CIO Capabilities Planning Guide
DoD Cyber Strategy, April 2015
DoD Information Technology Environment: Way Forward to Tomorrow's Strategic Landscape
DoDD 5144.02, DoD Chief Information Officer (DoD CIO)
DoDD 8000.01, Management of the DoD Enterprise (DoD IE)
Interorganizational Cooperation JP 3-08
Joint Communication Systems JP 6-0
Joint Operations JP 3-0
NDAA GFY 2018, TBD
NDAA GFY2016, S.1356
Net Centric Data Strategy
OMB A-130, Managing Information as a Strategic Resource
OMB M13-13, Open Data Policy – Managing Information as an Asset
Space Operations- JP 3-14

Process in which IEA is used	
CJCSI 3170.01I	Joint Capabilities Integration and Development System (JCIDS) including JCIDS Manual, February 2015, with errata as of 18 Dec 2015
CJCSI 5123.01G	Charter of the Joint Requirements Oversight Council
CJCSI 8010.01C	Joint Community Warfighter CIO
CJCSI 8410.02	Warfighting Mission Area (WMA) Principal Accrediting Authority (PAA) and WAM Authorizing Official Policy and Responsibilities
DoDD 7045.20	Capability Portfolio Management
DoDI 3741.01	National Leadership Command Capabilities (NLCC) Configuration Management (CM)
DoDI 5000.02	Operation of the Defense Acquisition System (DAS)
DoDI 5000.75	Business Systems Requirements and Acquisition
DoDI 5000.76	Accountability and Management of Internal Use Software (IUS)
DoDI 5015.02	DoD Records Management Program
DoDI 5134.16	Deputy Assistant Secretary of Defense for Systems Engineering (DASD(SE))
DoDI 8100.04	DoD Unified Capabilities (UC)
DoDI 8110.01	Mission Partner Environment (MPE) Information Sharing Capability Implementation for the DoD
DoDI 8115.02	Information Technology Portfolio Management Implementation
DoDI 8310.01	Information Technology Standards in the DoD
DoDI 8320.02	Sharing Data, Information, and Technology (IT) Services in the Department of Defense
DoDI 8320.07	Implementing the Sharing of Data, Information, and Information Technology (IT) Services in the Department of Defense
DoDI 8330.01	Interoperability of Information Technology (IT), including National Security Systems (NSS)
DoDI 8410.02	NETOPS for the Global Information Grid (GIG)
DoDI 8410.03	Network Management (NM)
DoDI 8420.01	Commercial Wireless Local-Area Network (WLAN) Devices, Systems, and Technologies
DoDI 8420.02	DoD Satellite Communications (SATCOM)
DoDI 8440.01	DoD Information Technology (IT) Service Management (ITSM)
DoDI 8500.01	Cybersecurity
DoDI 8510.01	Risk Management Framework (RMF) for DoD Information Technology (IT)
DoDI 8530.01	Cybersecurity Activities Support to DoD Information Network Operations
DoDI 8540.01	Cross Domain (CD) Policy
DoDI 8581.01	Information Assurance (IA) Policy for Space Systems Used by the Department of Defense
IPG	Joint Interoperability Test Command (JITC) Interoperability Process Guide



DIEA v3.0 Two Phases

Phase 1 (CY2017) Integrate and Automate		Phase 2 (CY2018) Operationalize	
Roles	<i>IEA Usage</i>	Roles	IEA Usage
DOTMLPF Solutions Developer	<i>Guide, Constrain and Inform Solutions</i>	Operational Commander	<i>Multi-Warfare COP/SA/C2</i>
Systems Engineer	<i>Guide, Constrain and Inform Solutions</i>	Cyberspace Operations CDR	<i>Cyber COP/SA/C2</i>
Test and Evaluation	<i>Extract IE Criteria for IE Test and Evaluation</i>	Capabilities Requirements Developer	<i>Identify and Prioritize Gaps</i>
		DoD CIO	<i>DoD-wide IT CPIC and PFM</i>
		Portfolio Manager	<i>Align Portfolio to Capabilities Requirements</i>



Unclassified

IEA Usage: As-Is

-- Manual, Document-based --

IEA User Roles

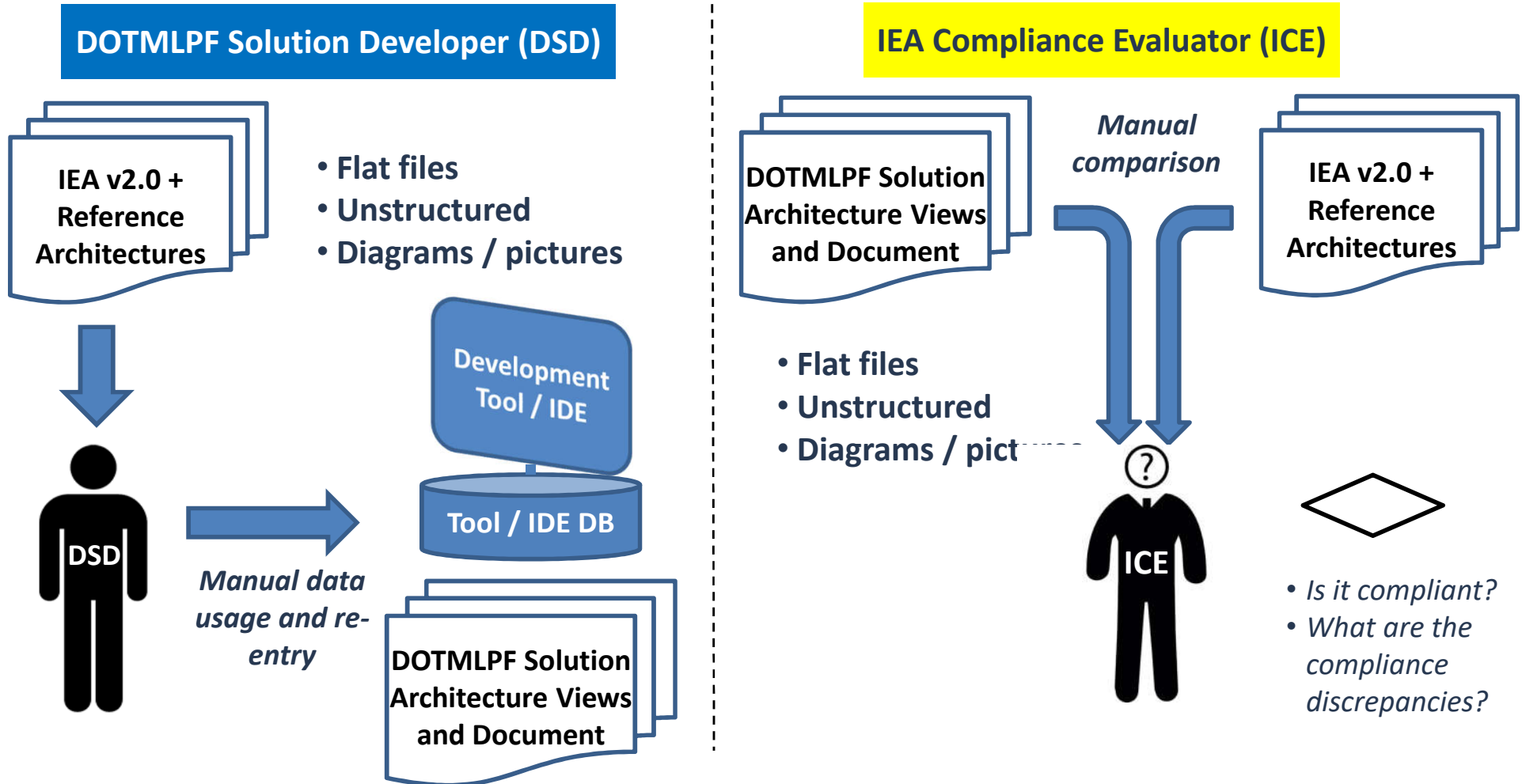

As-Is: Non-integrated, Manual



Unclassified

IEA Usage: To-Be

-- Automated, Data-based --

IEA User Roles

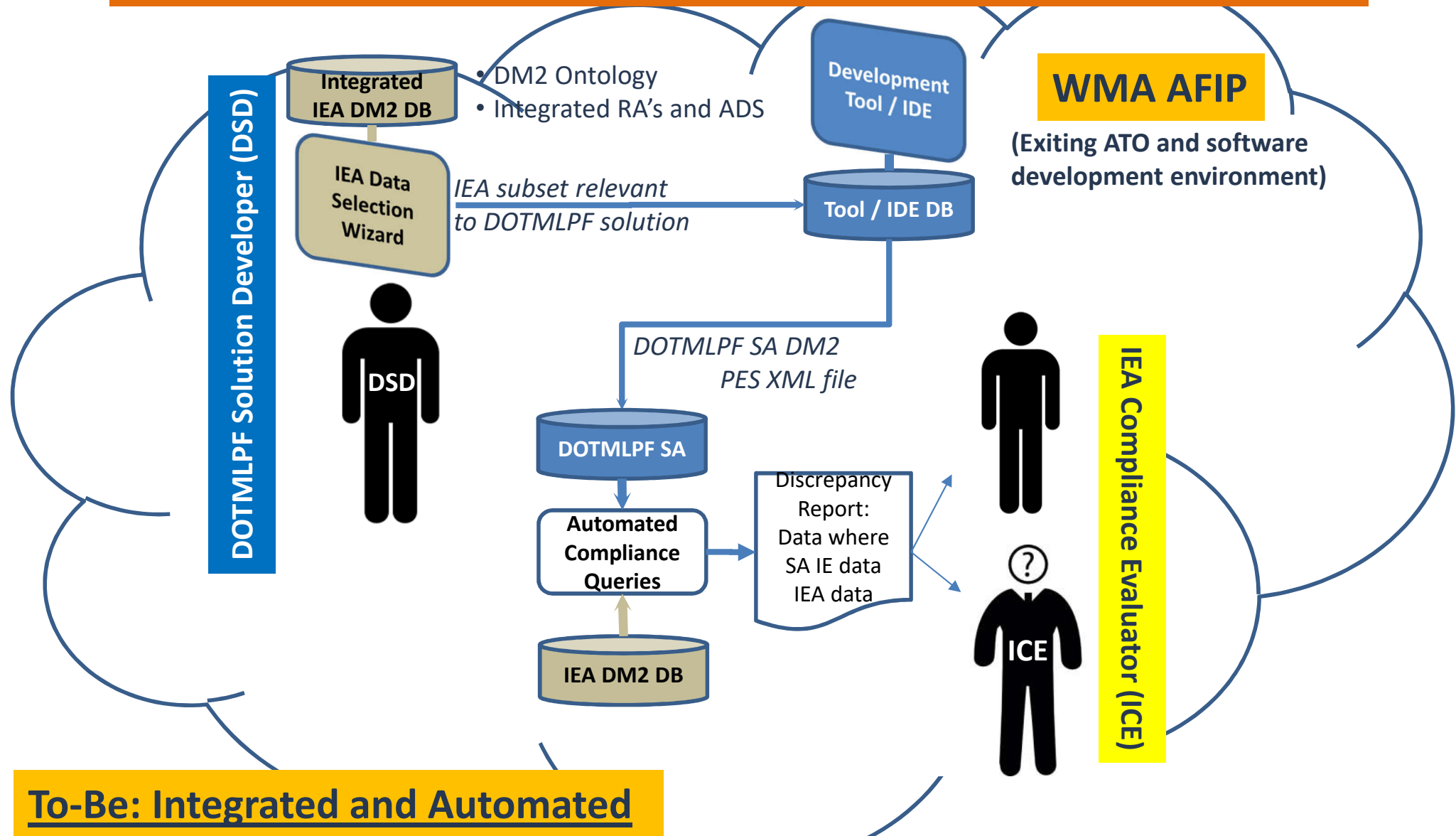

WMA AFIP

(Existing ATO and software development environment)

To-Be: Integrated and Automated

Unclassified



DIEA as Data: How to Achieve

On-going DIEA v3.0 Development

DIEA v3.0 Database Implementation

MS Access DB on DoD CIO drive

Prototype Tools @ contractor site

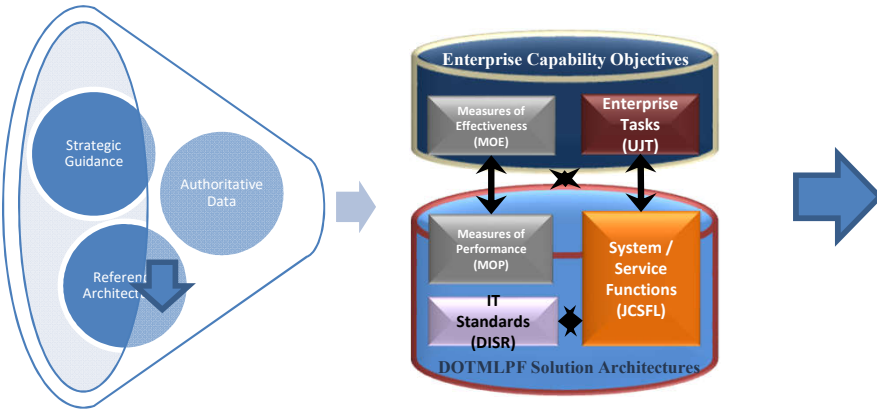

DataPhrase DM2 hierarchical triples tool for relationship data

DataTree DM2 hierarchical tool to build hierarchies

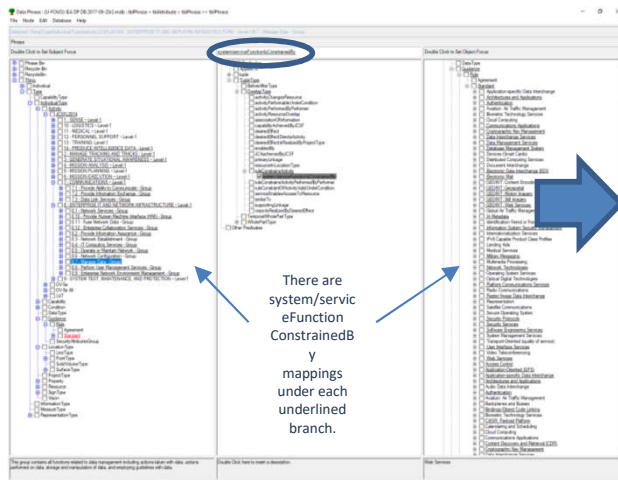

- Generate DM2 database from schema developed by working group.
- Import MS Access DB.
- Setup DB admin.
- Re-write 25K SLOC prototype VB and .NET for WMA AFIP environment
- Develop additional functionality not in prototypes based on Functional Requirements Document (FRD) developed by working group.

Oracle DB @ WMA AFIP

Java/JS on WMA AFIP

Leverage WMA AFIP Exiting ATO and Software Development Environment



Accompanying DoD Architecture Policy

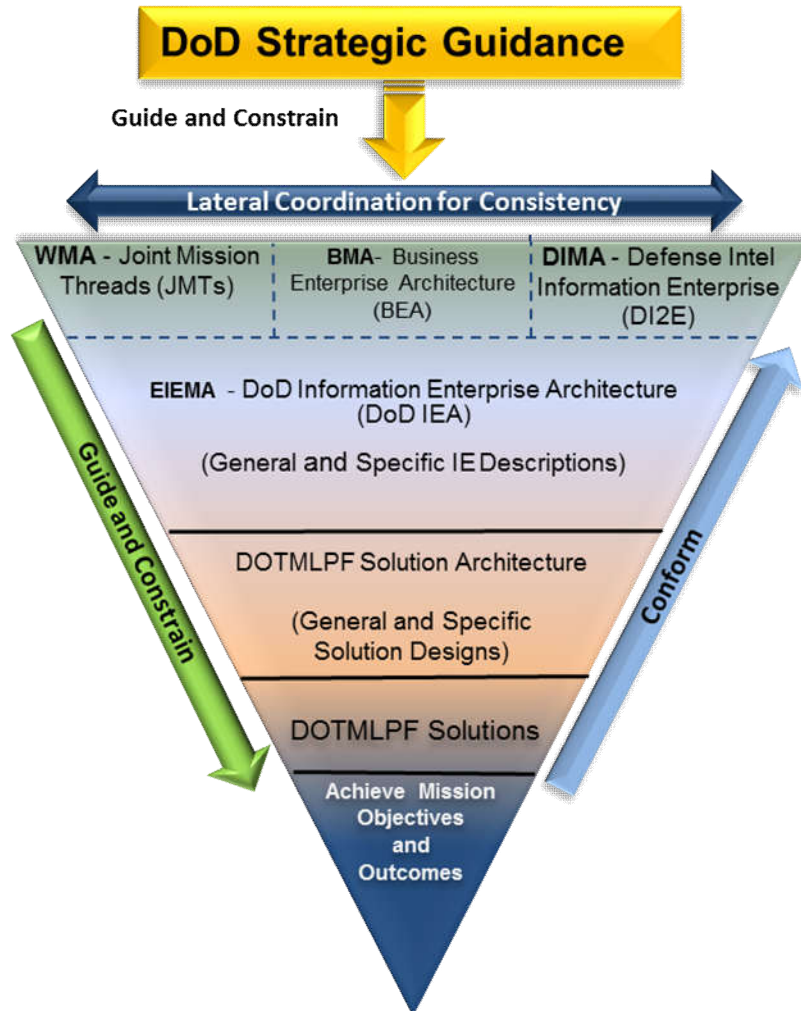

- Focus is on DoD Enterprise Architecture, not DoD IT Architecture
- Addresses development and use of architectural descriptions in support of DoD’s Core Processes
- Scope is top-level architectures down through DOTMLPF Solutions

WMA – Warfighting Mission Area
BMA – Business Mission Area
DIMA – Defense Intelligence Mission Area
EIEMA – Enterprise Information Environment Mission Area
DOTMLPF – Doctrine, Organization, Training, Materiel, Leadership and education, Personnel, and Facilities

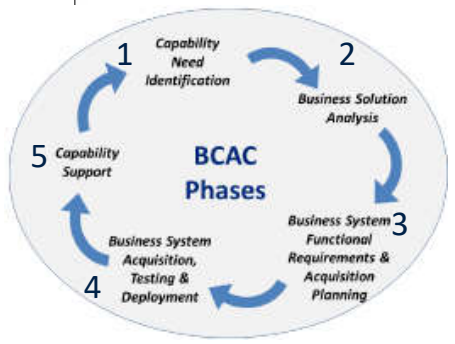
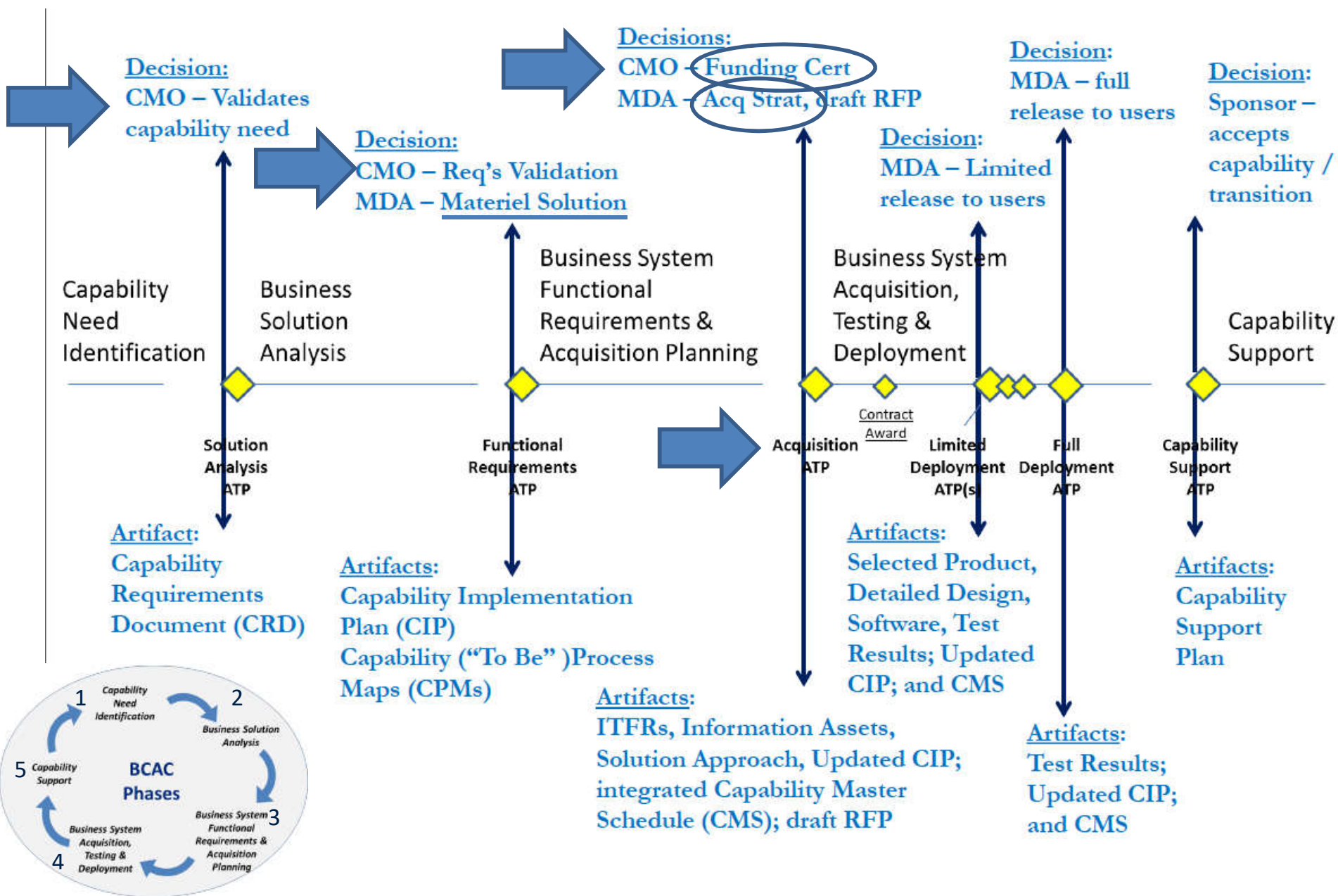



DIEA is Integrated in BEA

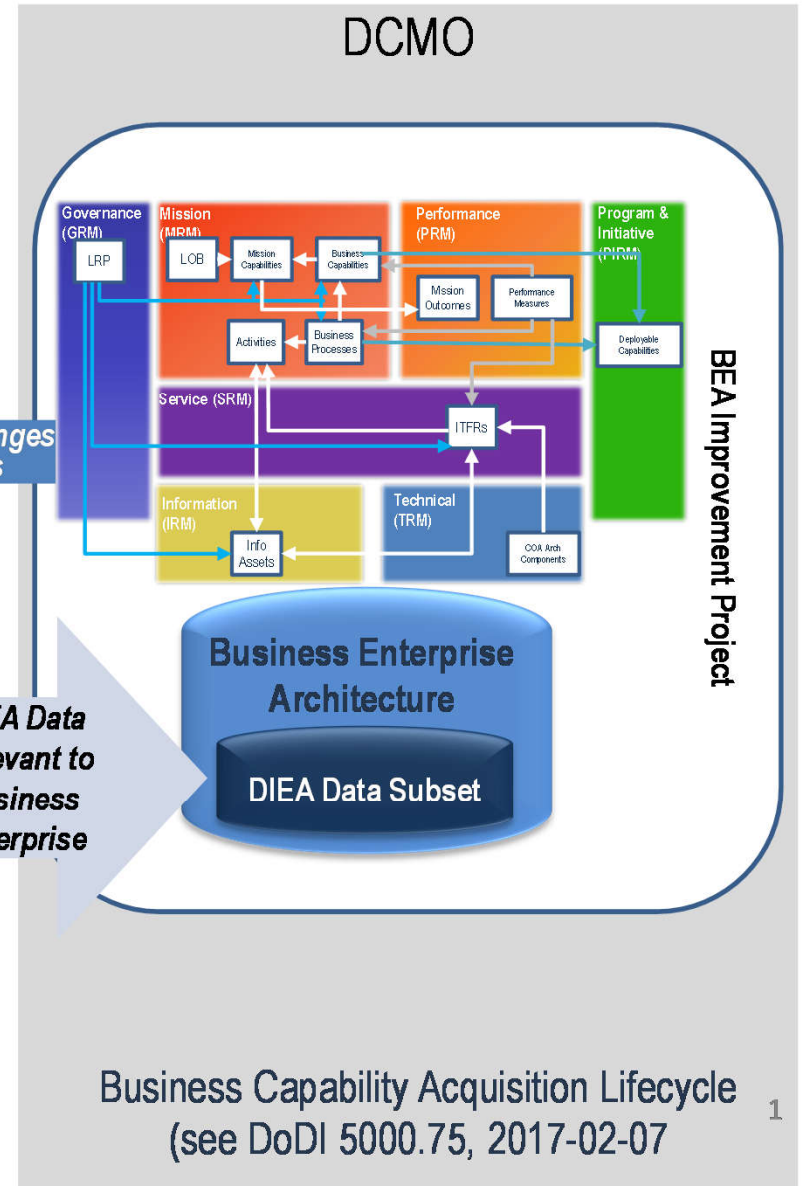
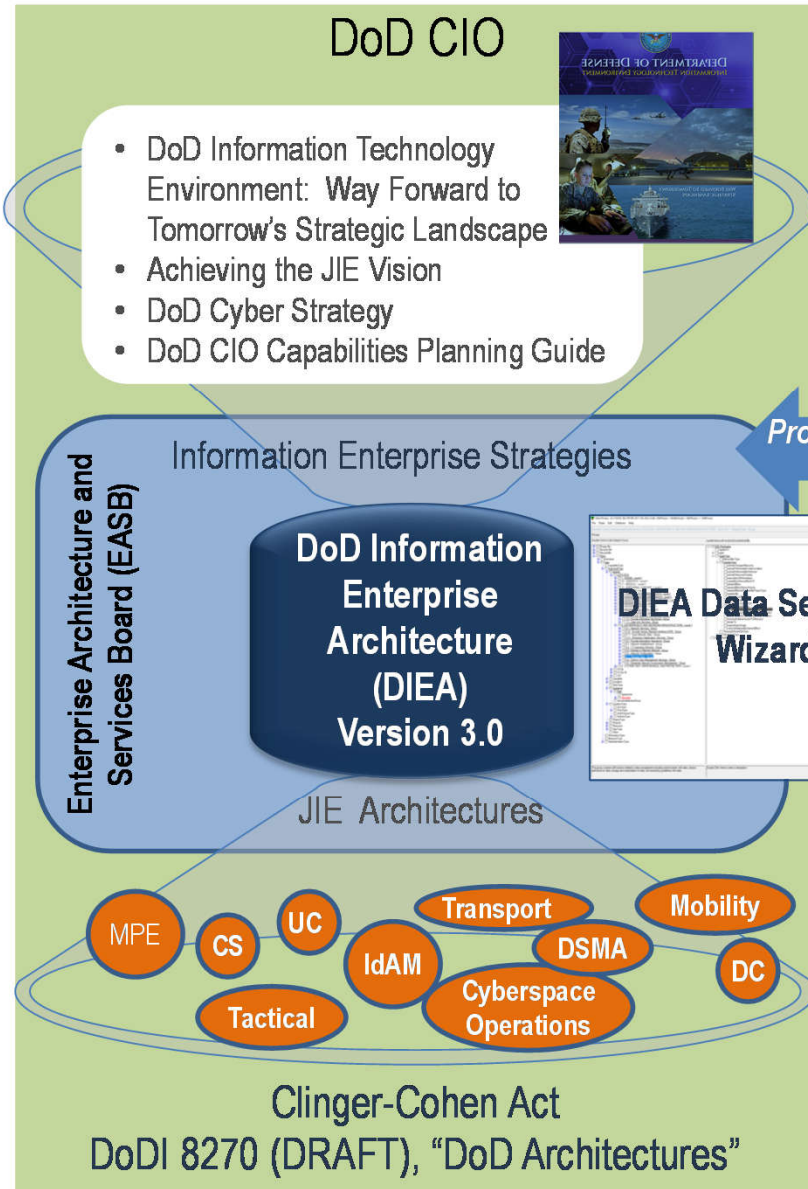



Using the BEA in BCAC Processes

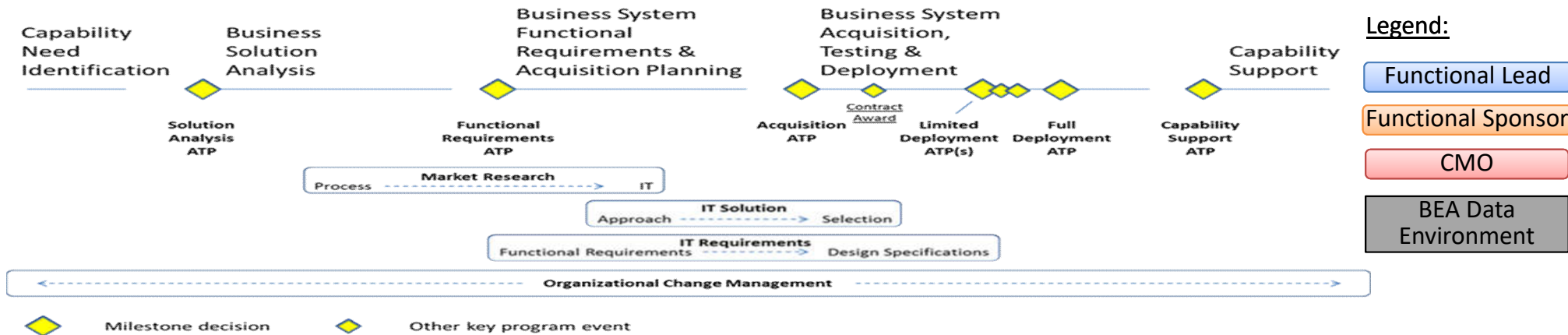

Use BEA to develop CRD and show alignment to functional strategies

Use BEA to maximize use of existing business solutions

Use BEA to maximize reuse of existing business IT solutions

Capture actual performance data for deployed capabilities and IT systems

Use BEA to identify any existing capabilities that can be adopted

Use BEA to develop a CIP and CPMD

Use BEA to evaluate interdependencies between processes and data and resolve any conflicts

Use BEA to evaluate interdependencies between systems and resolves any conflicts

Use BEA to support change control and determination of changes that could trigger a new BCAC

Use BEA to ensure alignment with functional strategies

Use BEA to validate sufficient BPR has been completed

Assess for BEA compliance as part of certification

Incorporate CRD architecture content in to BEA

Incorporate CPMD architecture content in BEA

Incorporate performance data into BEA



Backups



Recap: Scope of Information Enterprise (IE) Architecture

Authoritative Definitions

DoD Information Enterprise (IE)	DoD Directive 8000.01, Management of the Department of Defense Information Enterprise	<i>The DoD information resources, assets, and processes required to achieve an information advantage and share information across the Department of Defense and with mission partners. It includes: (a) the information itself and the Department’s management over the information life cycle; (b) the processes, including risk management, associated with managing information to accomplish the DoD mission and functions; (c) activities related to designing, building, populating, acquiring, managing, operating, protecting, and defending the information enterprise; and (d) related information resources such as personnel, funds, equipment, and IT, including national security systems.</i>
Information Environment	JP 3-13, Information Operations	<i>(DOD) The aggregate of individuals, organizations, and systems that collect, process, disseminate, or act on information.</i>
Joint Information Environment (JIE)	JIE Initial Capabilities Document (ICD)	<i>The Joint Information Environment (JIE) is a single, secure, reliable Department of Defense (DOD)-wide information environment, comprised of shared information technology (IT) infrastructure, shared data, enterprise services, and a single security architecture to achieve full spectrum superiority, improve mission effectiveness, increase security and realize IT efficiencies.</i>
DoD Information Network (DoDIN)	Joint Pub 6-0, Joint Communications System)	<i>The set of information capabilities, and associated processes for collecting, processing, storing, disseminating, and managing information on-demand to warfighters, policy makers, and support personnel, whether interconnected or stand-alone, including owned and leased communications and computing systems and services, software (including applications), data, security services, other associated services, and national security systems.</i>
Defense Information Systems Network (DISN)	Joint Pub 6-0, Joint Communications Systems	<i>(DOD) The integrated network, centrally managed and configured by the Defense Information Systems Agency to provide dedicated point-to-point, switched voice and data, imagery, and video teleconferencing services for all Department of Defense activities.</i>



Relationships among Key IE Definitions

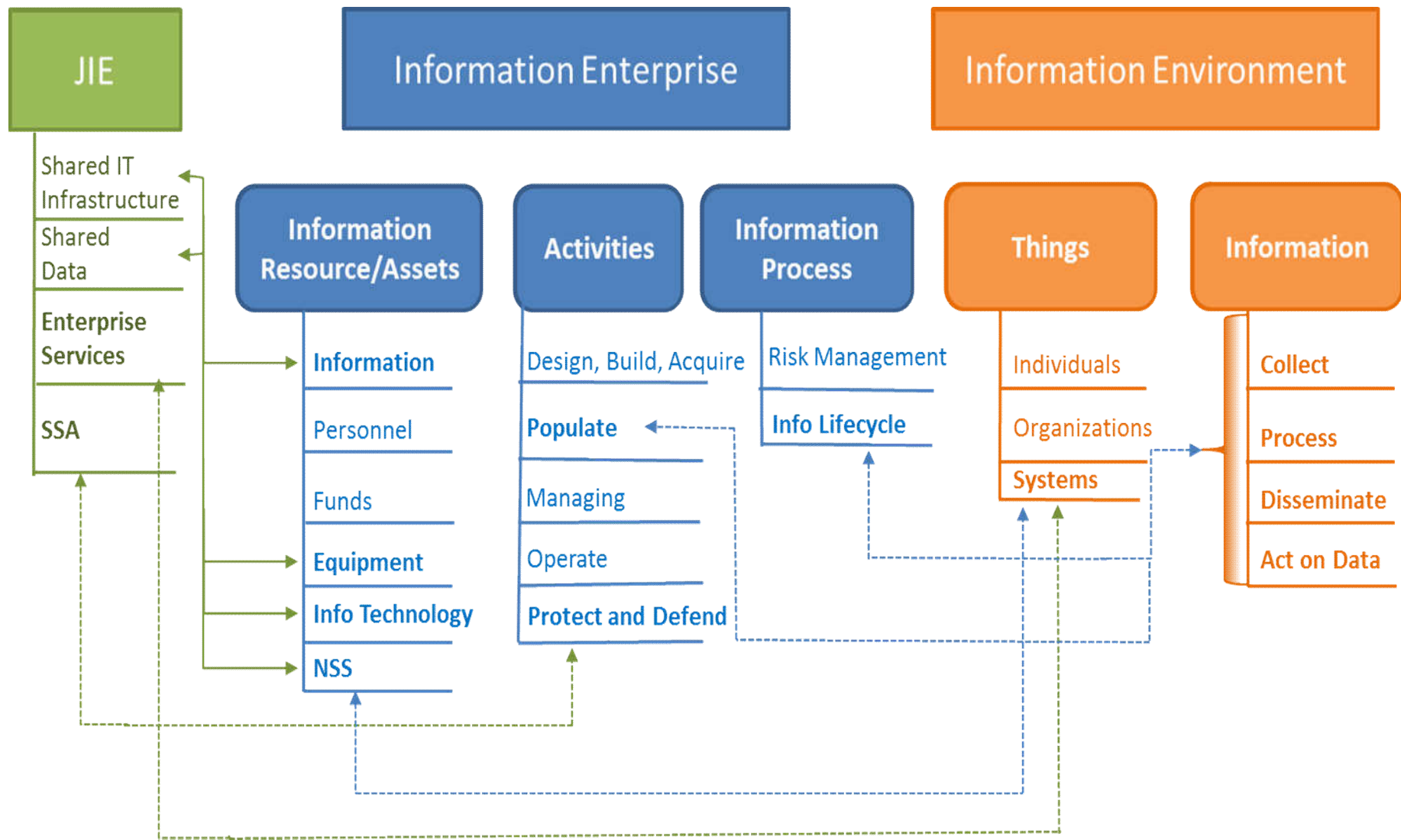



DIEA v3.0 Two Phases

Roles	IEA Usage	Development Phase
DOTMLPF Solutions Developer	Guide, Constrain and Inform Solutions	Phase 1 (CY2017)
Systems Engineer	Guide, Constrain and Inform Solutions	
Test and Evaluation	Extract IE Criteria for IE Test and Evaluation	
Operational Commander	Multi-Warfare COP/SA/C2	Phase 2 (CY2018)
Cyberspace Operations CDR	Cyber COP/SA/C2	
Capabilities Requirements Developer	Identify and Prioritize Gaps	
DoD CIO	DoD-wide IT CPIC and PFM	
Portfolio Manager	Align Portfolio to Capabilities Requirements	



Phase I Data

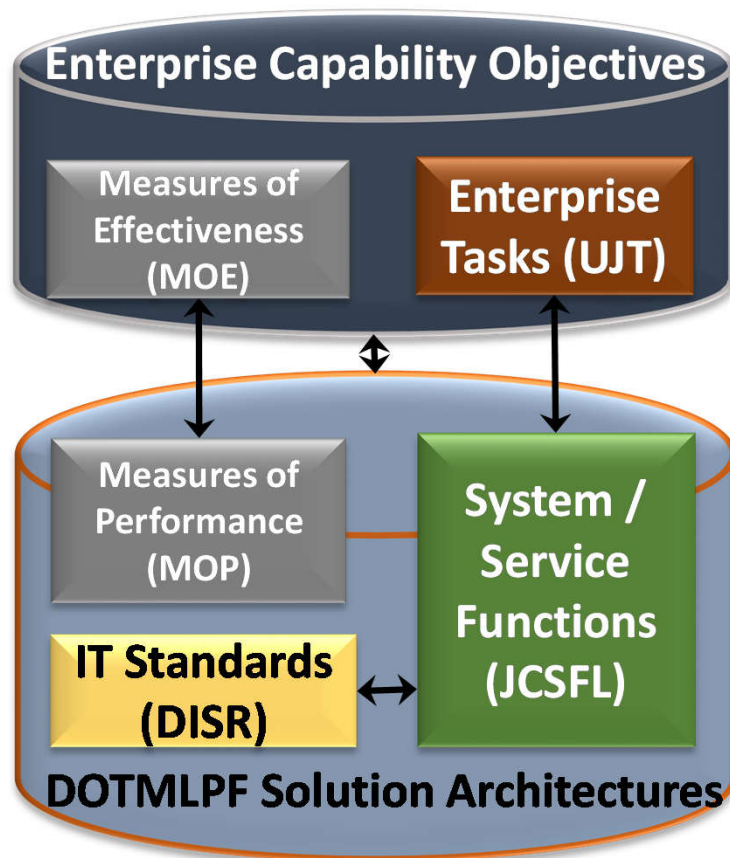

DOTMLPF solutions developers will be able to import relevant portions of the IEA database into their development environment for integration with and further refinement of their solution. The result is that the IEA, including cyber security architecture, will be baked-in to the solution. Automated import:

- Reduces DOTMLPF development costs and time because they don't have to refer to the IEA manually.
- Results in DOTMLPF solutions that are more interoperable because of common import of information exchange methods and enterprise standards and system / service functional characteristics.
- Results in DOTMLPF solutions that are more secure because an import reduces chances of misinterpretation or oversights that might occur manually.
- Results in DOTMLPF solutions that are better aligned with enterprise objectives because the solution functionally is traceable to Enterprise Tasks and performance characteristics (MOP) are traceable to Enterprise Capability Objective metrics (MOE).

Benefits will accrue across all levels of the DoD and all its core processes



Proposed BEA Framework Metadata

Note: Additional work is required to define boxes and lines represented

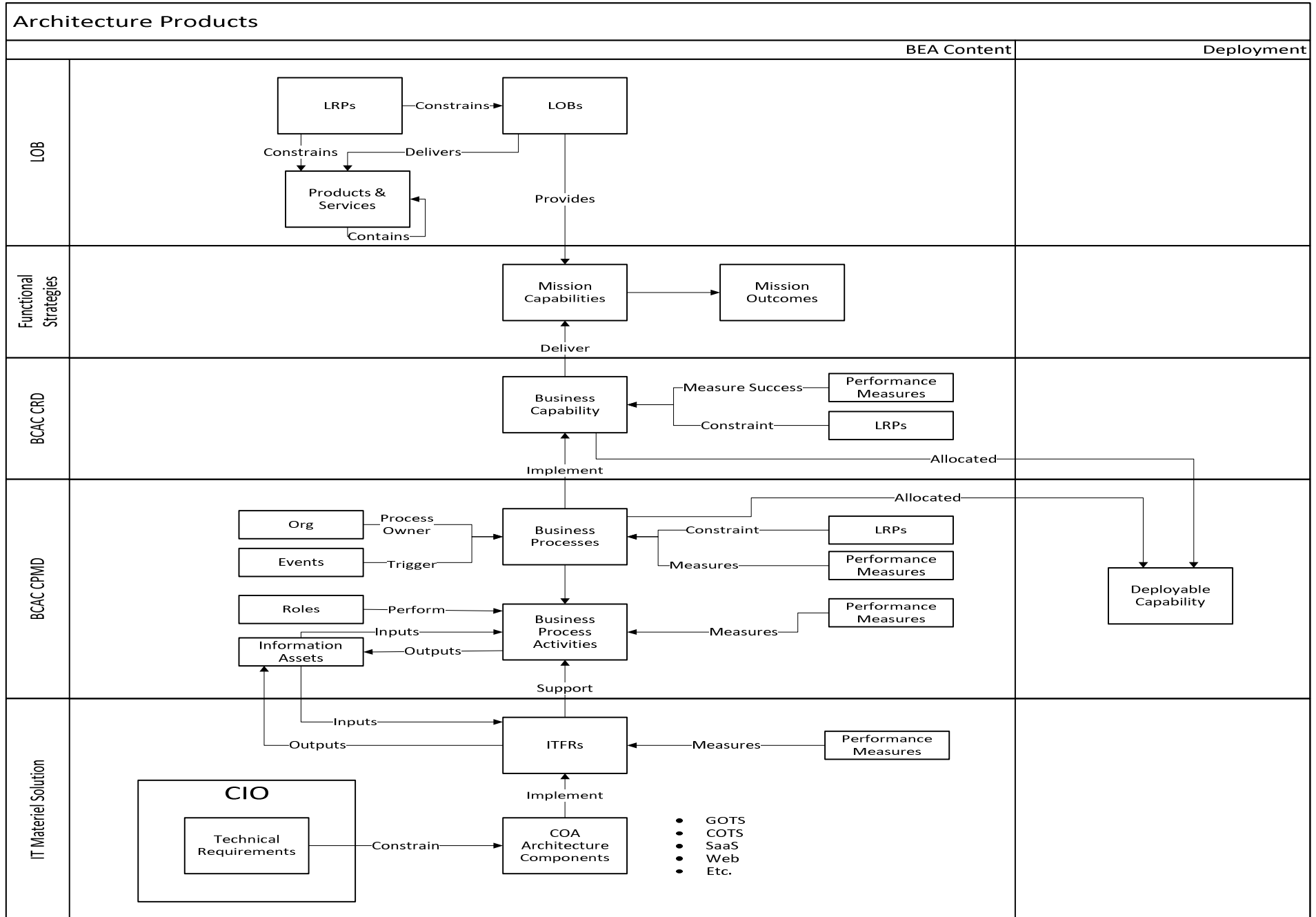



Leveraging Existing Data

IE Reference Architectures:

CS RA
OCRA'
UCRA
DC RA
MPE RA
IdAM RA
NMI
DSMA'

**DoD
Authoritative
Architecture
Data:**

UJTL – Activity Structure
JCSFL – System/Service Functions
JCA – Relate to Capability
DISR -- Standards

**JTSO Architectures for
which there is no
corresponding RA:**

DMCC^{ED}
DMUC^{ED}
SATCOM GW^{TAD}
JIE WAN^{TAD}



Phase I DB Top-Level

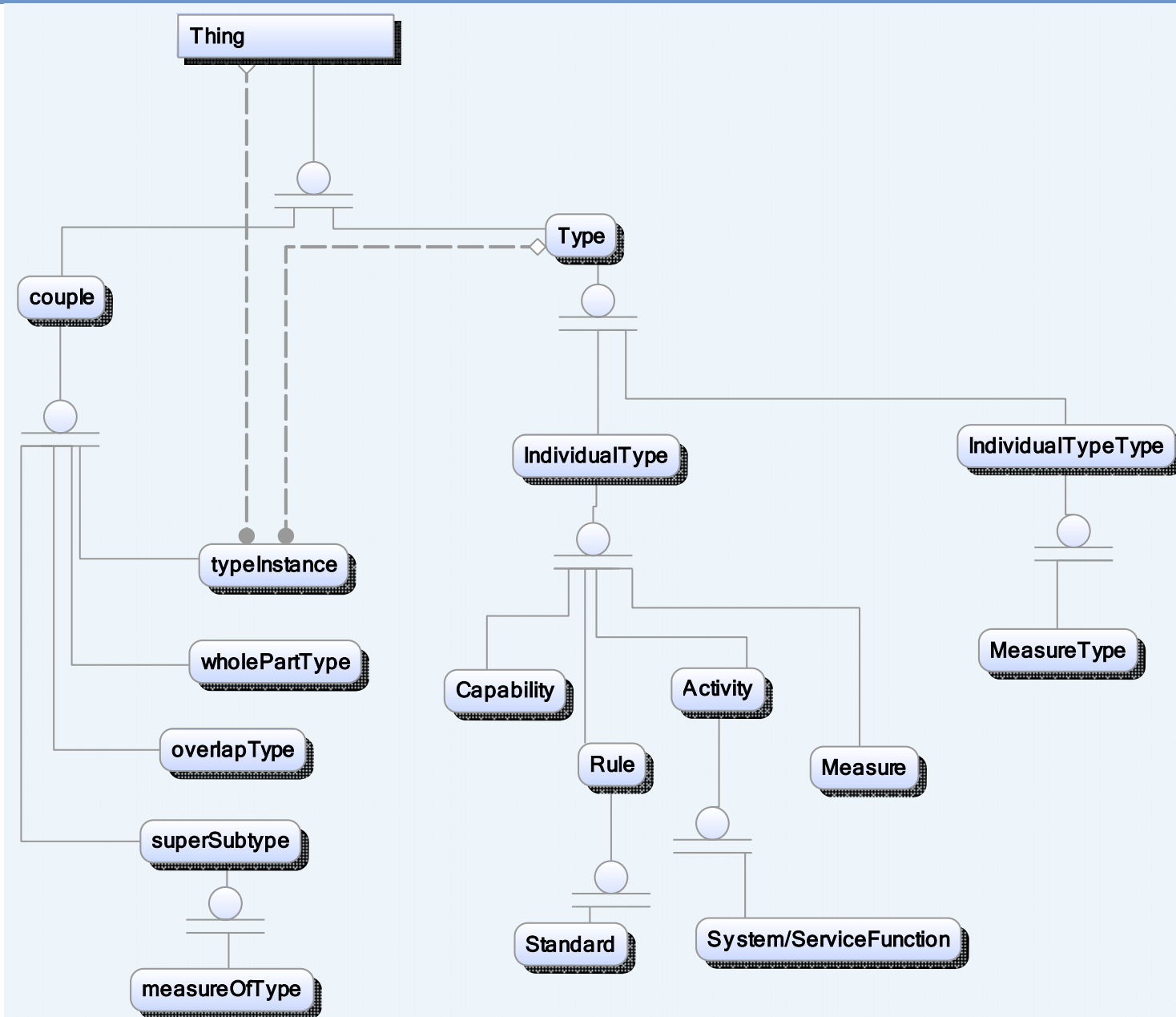



DB Tools Access

Data Phrase : (U-FOUO) IEA DP DB 2017-06-22.mdb : tblPhrase > tblAttribute > tblPhrase >> tblPhrase

File Node Edit Database Help

Selected: Thing\Type\IndividualType\Activity\UJTL_JCA_JC_ST UJT Definitions\OP 5 - Provide Command and Control (C2)\OP 5.1 - Integrate Information\OP 5.1.2 - Manage Means of Communicating Operational Information

Created Phrase: 4.5.6 - Network Management (NM) similarTo OP 5.1.2 - Manage Means of Communicating Operational Information

4.5.6 - Network Management (NM)	similarTo	Double Click to Set Object Focus
<ul style="list-style-type: none">Capability TypeIndividual Type<ul style="list-style-type: none">ActivityCapability<ul style="list-style-type: none">1 - NETOPS<ul style="list-style-type: none">1.2 - DODIN Operations<ul style="list-style-type: none">1.2.1 - DODIN Operations Management1.2.2 - Enterprise Service Management1.2.3 - Cybersecurity Measures Operations1.2.5 - Configuration Control and Patching1.2.6 - DODIN Secure Management1.2.7 - Security Systems Operations1.2.8 - Infrastructure and Services Monitoring4.4 - Continuity of Operations<input checked="" type="checkbox"/> 4.5.6 - Network Management (NM)5.3 - Configuration Management5.4 - Out of Band Management1.2.4 - Cyber Force Training1.4 - Information Enterprise Situational Awareness11.3.1 - Defensive Cyberspace OperationsSpectrum Management2 - MP Interoperability3 - DC4 - NW5 - CS6 - MOB7 - ES8 - Cloud9 - Information Sharing	<ul style="list-style-type: none">individualResourceInLocation<ul style="list-style-type: none">superSub TypetemporalWholeParttypeInstancewholePartTuple Type<ul style="list-style-type: none">BeforeAfterTypeOverlap Type<ul style="list-style-type: none">activityChangesResourceactivityPerformableUnderConditionactivityPerformedByPerformeractivityResourceOverlapassociationOfInformationdesiredEffectdesiredEffectDirectsActivitydesiredEffectIsRealizedByProjectTypeenabledByprimaryLinkageresourceInLocationTyperuleConstrainsActivityruleConstrainsActivityPerformedByPerformerruleConstraintOfActivityValidUnderConditionserviceEnablesAccessToResource<input checked="" type="checkbox"/> similarTosupportingLinkagevisionIsRealizedByDesiredEffectTemporalWholePartTypeWholePartTypeOther Predicates	<ul style="list-style-type: none">UJTL_JCA_JC_ST UJT Definitions<ul style="list-style-type: none">OP 1 - Conduct Operational ManeuverOP 2 - Conduct Joint Intelligence OperationsOP 3 - Employ FiresOP 4 - Provide Operational SustainmentOP 5 - Provide Command and Control (C2)<ul style="list-style-type: none">OP 5.1 - Integrate Information<ul style="list-style-type: none">OP 5.1.1 - Communicate Operational InformationOP 5.1.10 - Implement Electromagnetic Spectrum Management, Policy, PlOP 5.1.11 - Provide Combat IdentificationOP 5.1.12 - DELETEDOP 5.1.13 - Coordinate with Security ContractorsOP 5.1.14 - Establish a Collaborative Environment<input checked="" type="checkbox"/> OP 5.1.2 - Manage Means of Communicating Operational InformationOP 5.1.3 - Determine Commander's Critical Information Requirements (CCIIOP 5.1.4 - Process InformationOP 5.1.5 - Monitor Strategic SituationOP 5.1.6 - Preserve Historical Documentation of Joint/Combined OperatioOP 5.1.7 - Employ Combat Camera (COMCAM)OP 5.1.8 - Execute Command, Control, Communications, and Computers ((OP 5.1.9 - Coordinate Information Assurance (IA) ProceduresOP 5.2 - Assess Operational SituationOP 5.3 - Prepare Plans and OrdersOP 5.4 - Command Subordinate ForcesOP 5.5 - Command and Control Joint Force HeadquartersOP 5.6 - Coordinate Information Operations (IO)OP 5.7 - Coordinate and Integrate Joint/Multinational and Interagency SupportOP 5.8 - Conduct Public Affairs (PA)

The execution of the set of functions required for controlling, planning, allocating, deploying, coordinating and monitoring the resources of a telecommunications network, including performing functions such as initial network planning frequency allocation, predetermined

Represents that an activity was / is / will be the cause of change in the effected object with a before-after relationship.

To manage (determine, establish, direct, or control) the means used in sending or receiving operational information of any kind and to use DOD standard communication networks and modes, where possible, for obtaining or sending operational information. Produce Annex K for all deliberate plans and operations orders and monitor

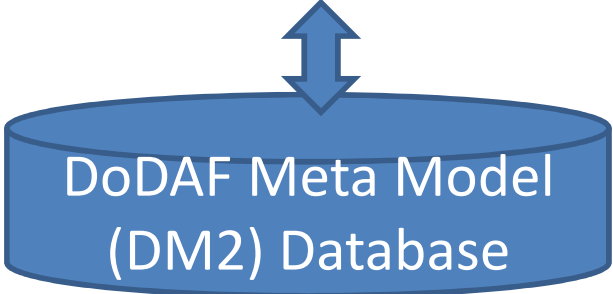



Future Architecture, Standards, and ADS Integration

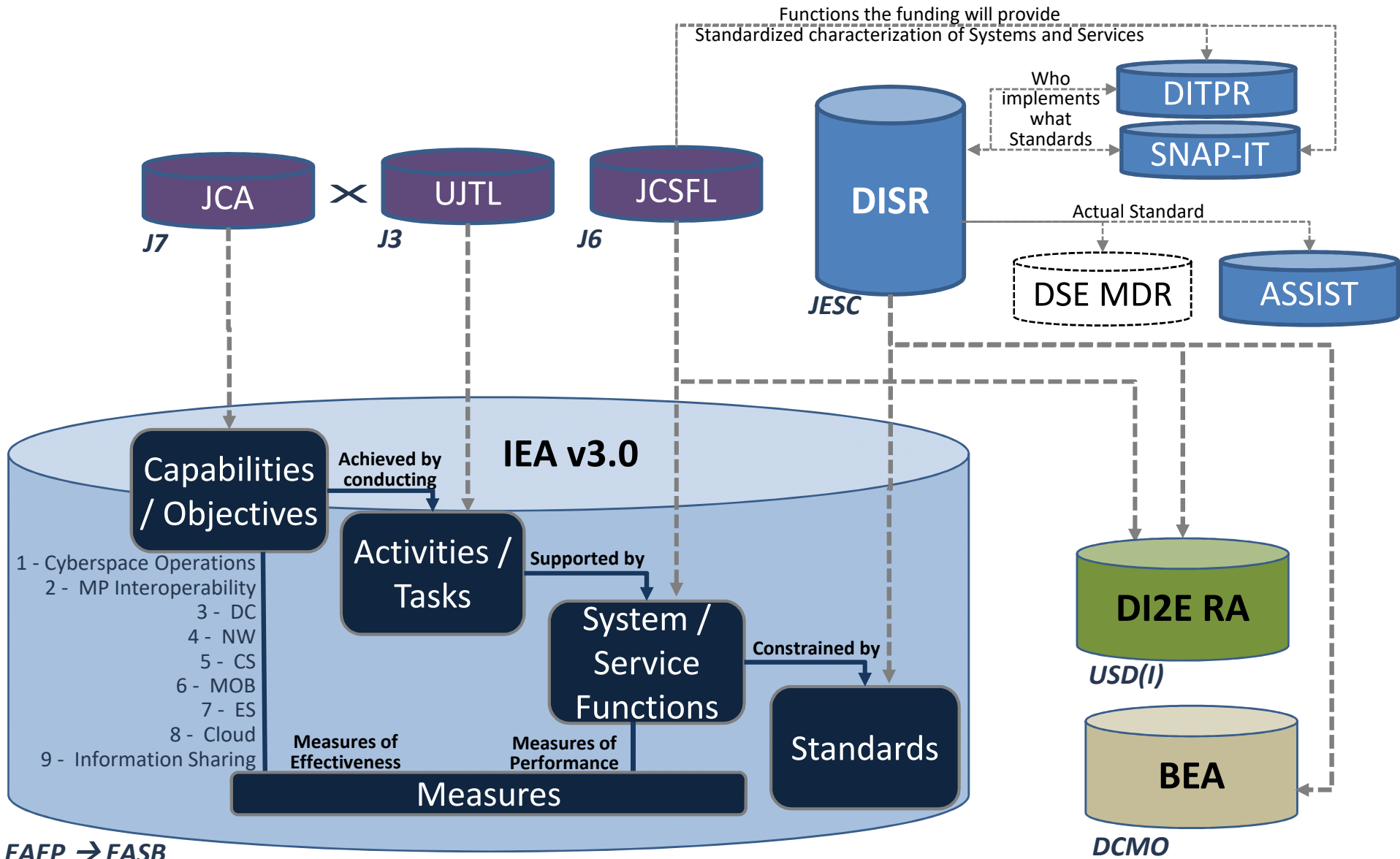



DoD Architecture Policy

- Defines Purpose, Applicability, Policy (9), and Responsibilities; Procedures not addressed
- Focus is on DoD Enterprise Architecture, not DoD IT Architecture
- Applies to all four Mission Areas
- Addresses development and use of architectural descriptions in support of DoD's Core Processes
- Scope is Mission Area Architectures down through DOTMLPF Solutions
- Conducting comment resolution for internal CATMS Review



Other Key Aspects of the DoD EA

- DoD architecture descriptions will be developed and maintained according to a configuration management process as defined in this instruction.
- DoD architecture descriptions will be conformant with DoD Architecture Framework (DoDAF).
- DoD architecture description data will be shared, discoverable, accessible, and understandable across governance processes defined in references (b-j).
- DoD architecture description data will be traceable to and consistent with authoritative data.
- DoD architecture descriptions will be maintained and updated to address new requirements.